

HYGEA

# NÁVOD PRO INSTALACI

IW-H20L

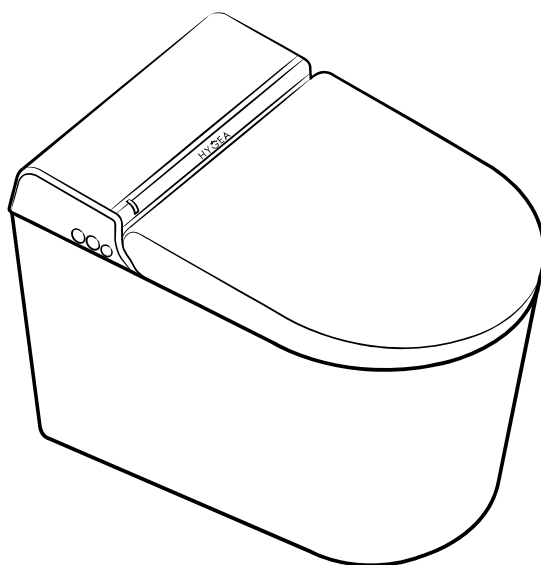

HYGEA

1

### Vodovodní a elektrické přípojky

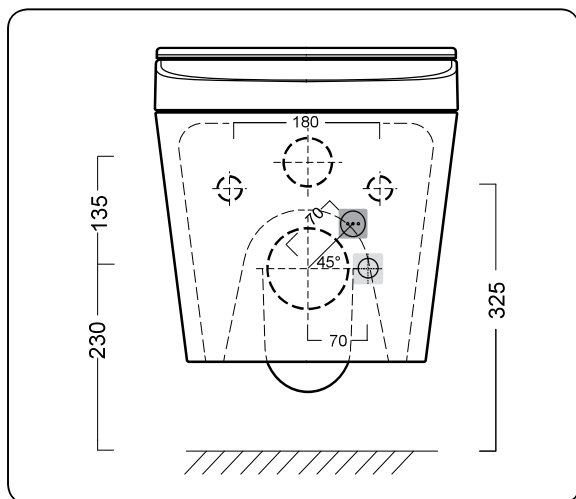

- Délka ohebné hadice: 150 mm od zdi - 3/8" F
- Délka napájecího kabelu: 250 mm od zdi

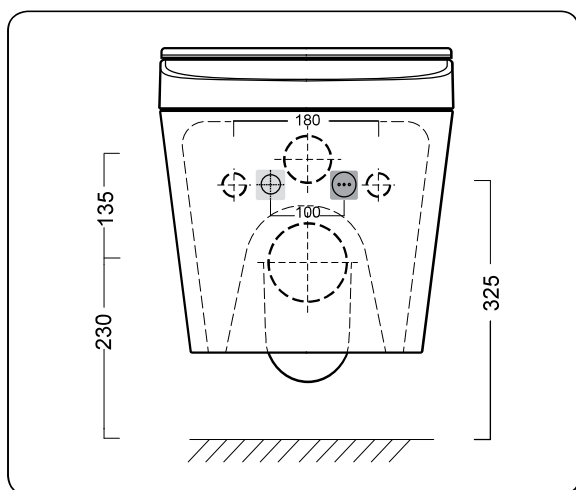

- Délka ohebné hadice: 270 mm od zdi - 3/8" F
- Délka napájecího kabelu: 220 mm od zdi

2

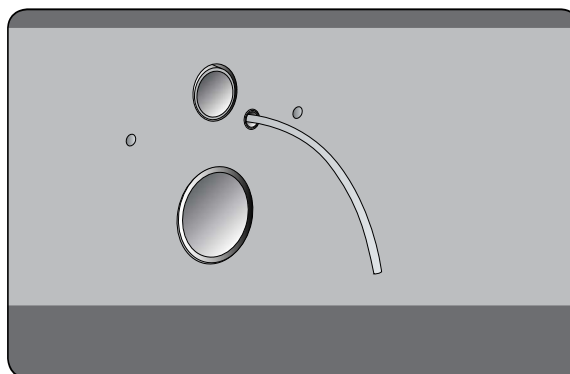

2-1

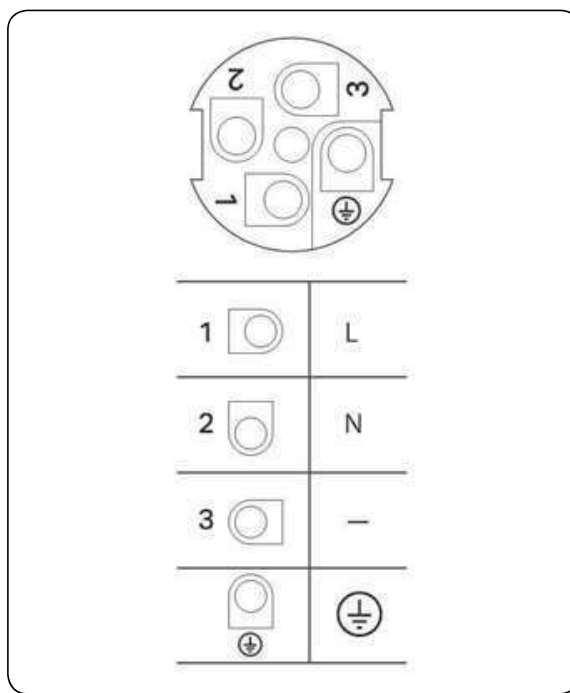

## 2-2

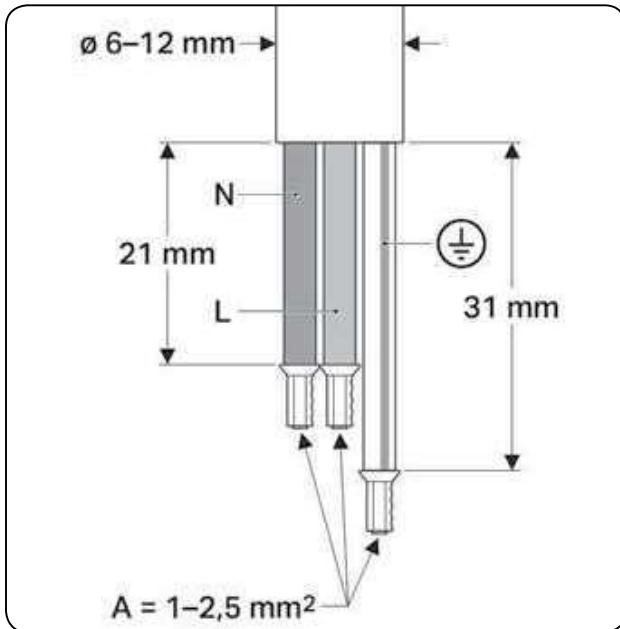

## 2-3

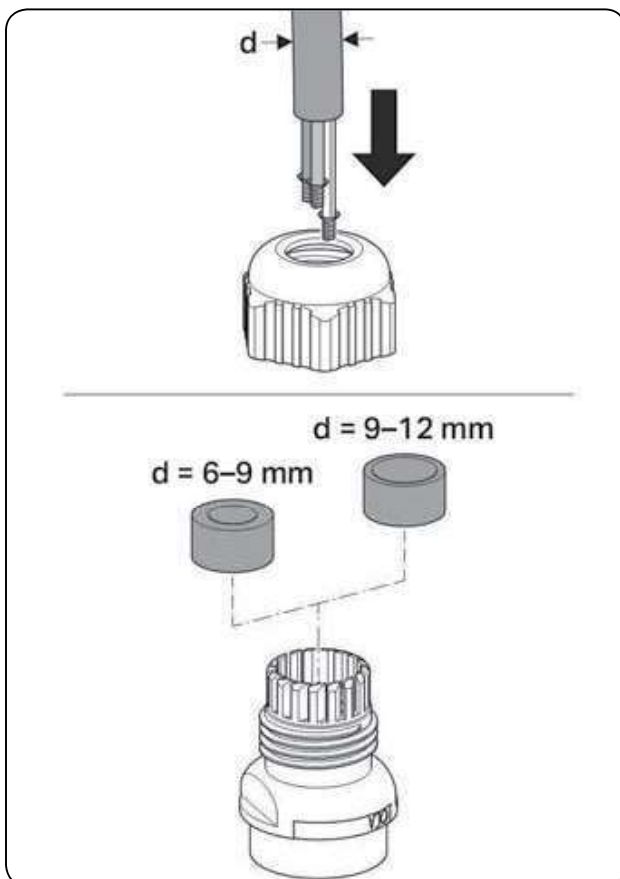

## 2-4

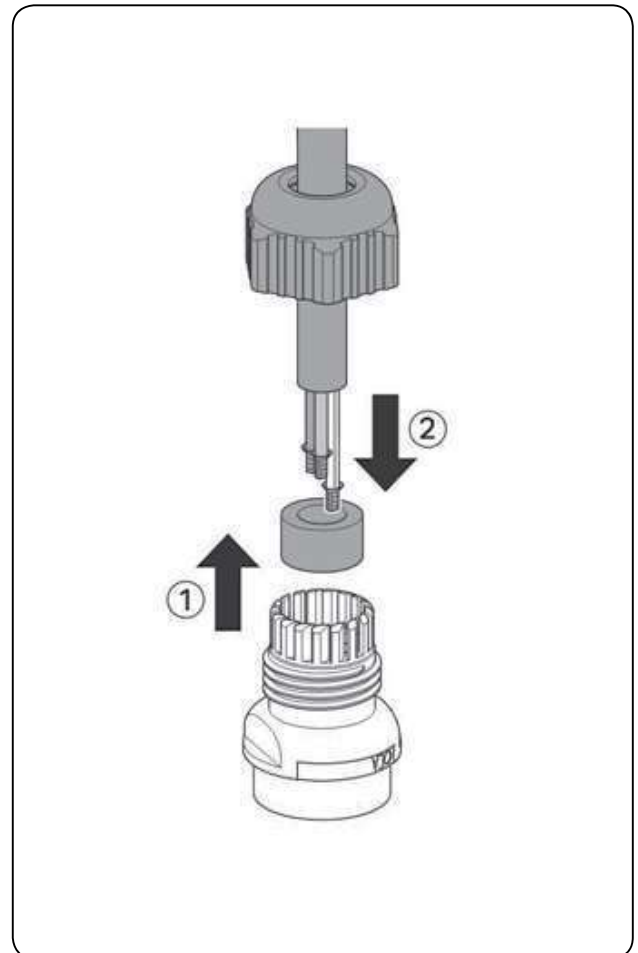

## 2-5

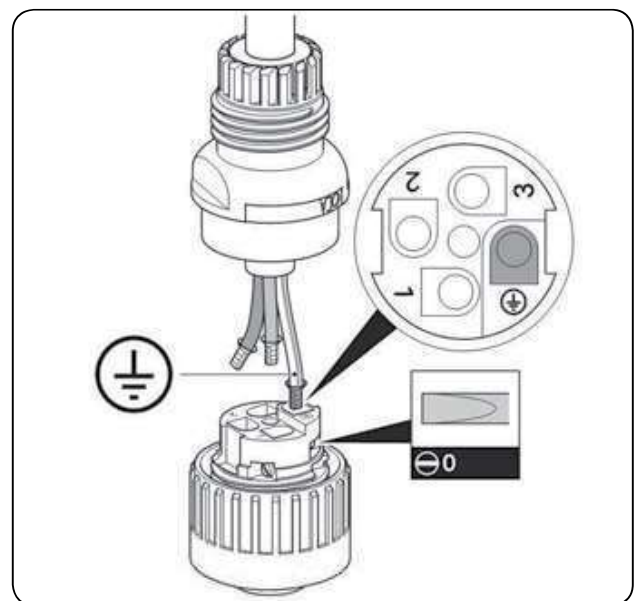

## 2-6

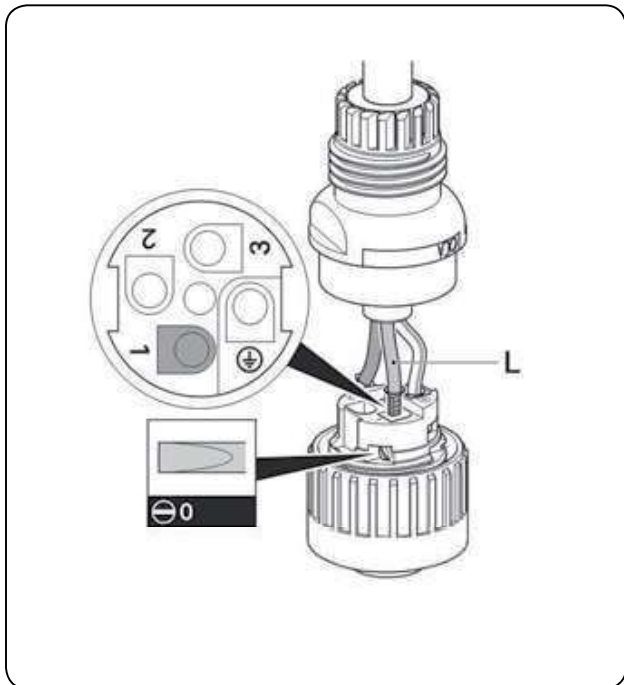

## 2-8

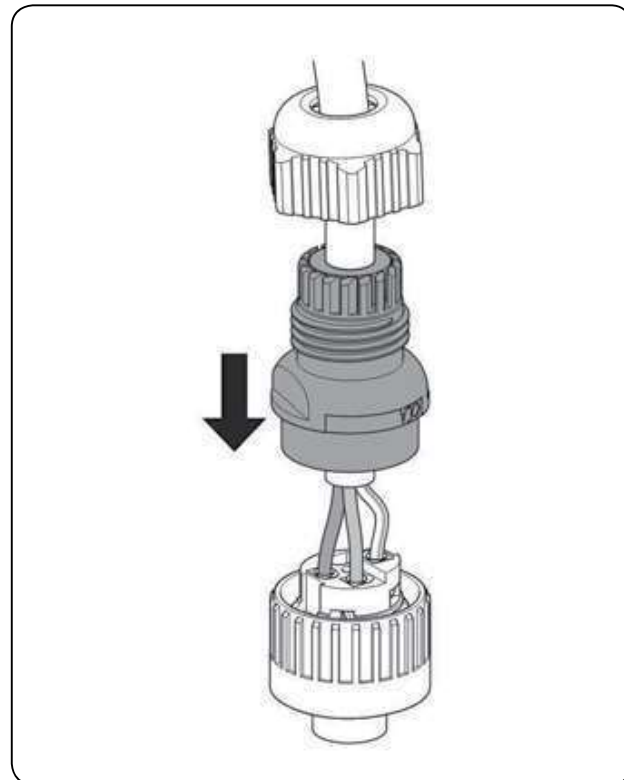

## 2-7

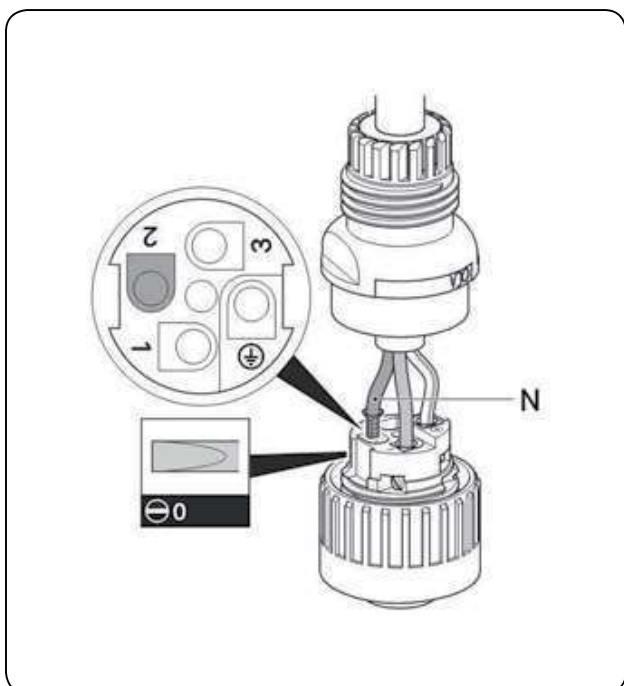

## 2-9

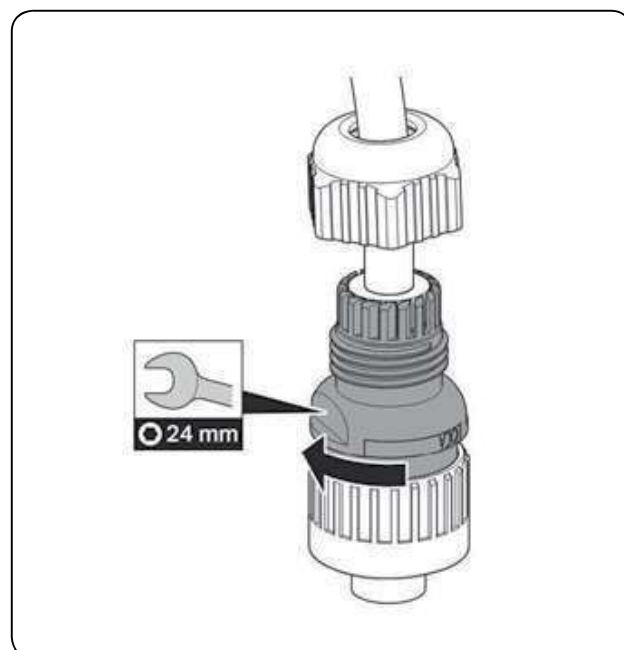

## 2-10

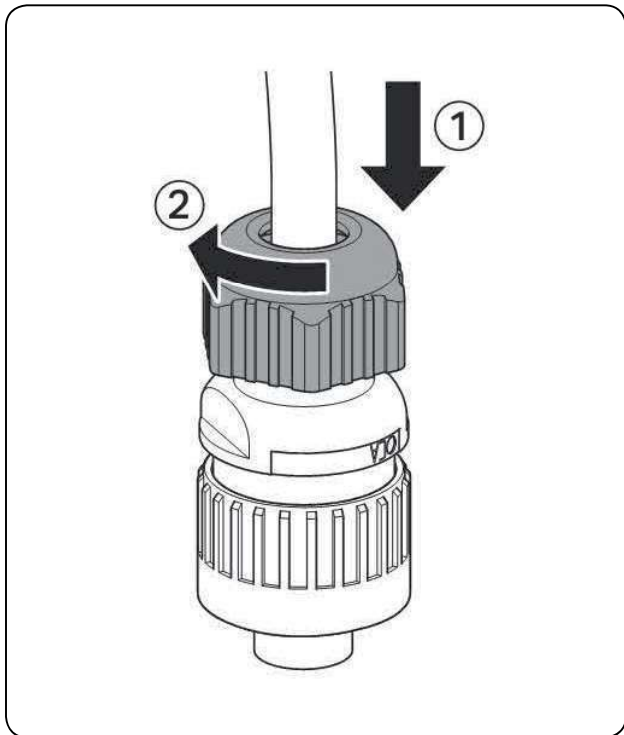

## 2-11

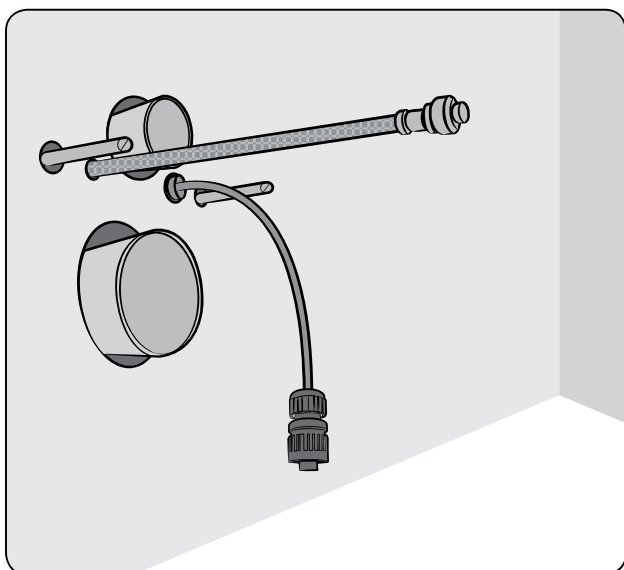

# Obsah balení - Hygea

**3**

**3-1**

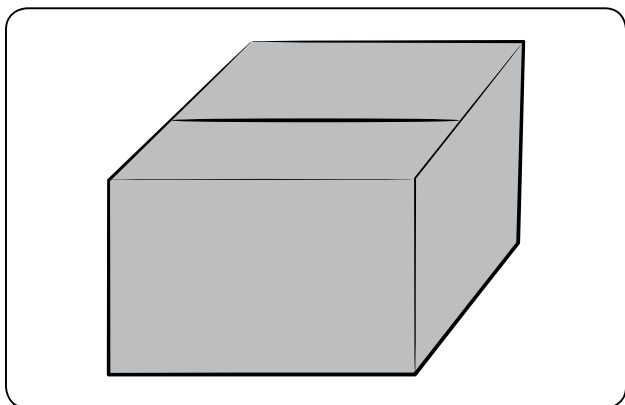

**3-2**

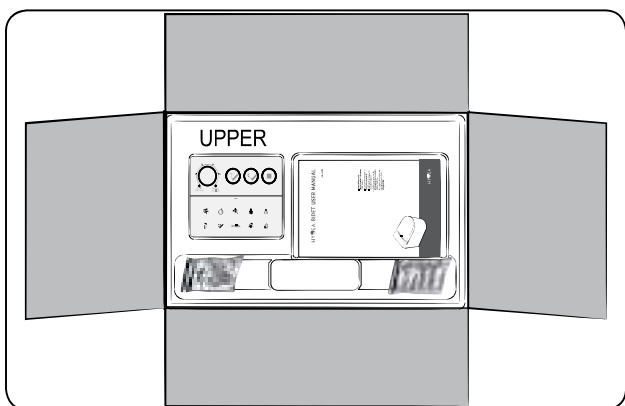

**3-3**

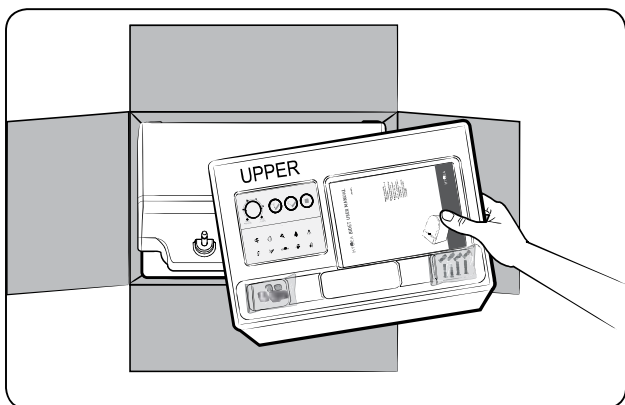

**3-4**

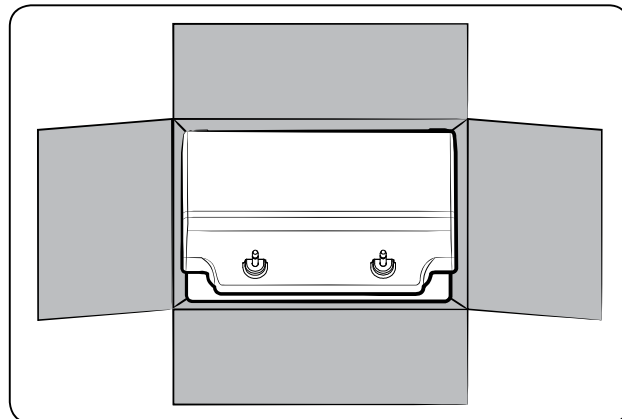

**3-5**

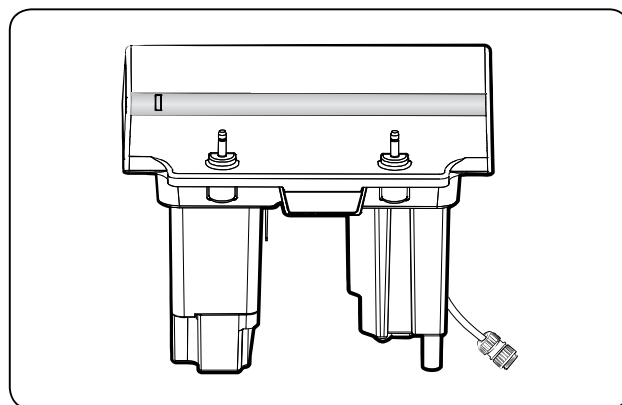

### 3-6

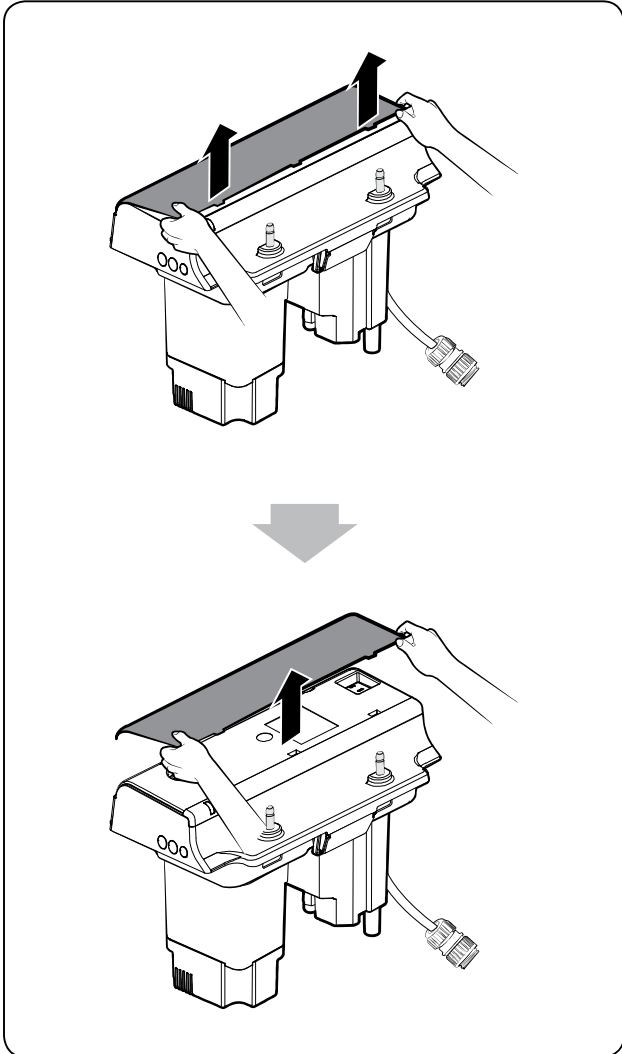

### 3-7

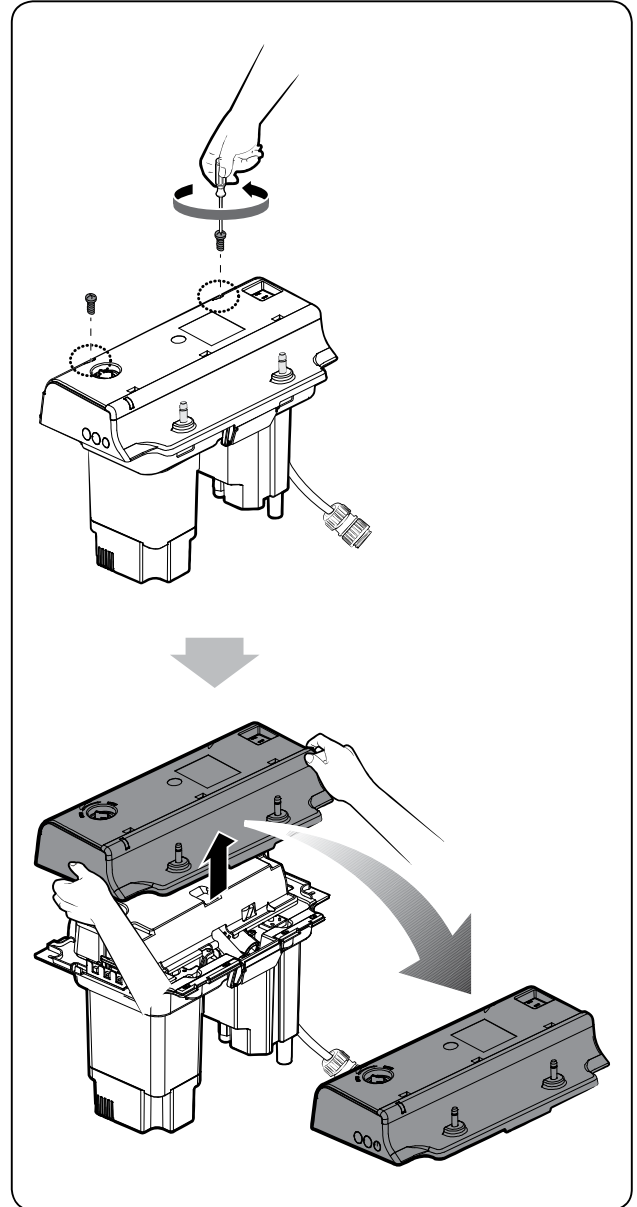

4

4-1

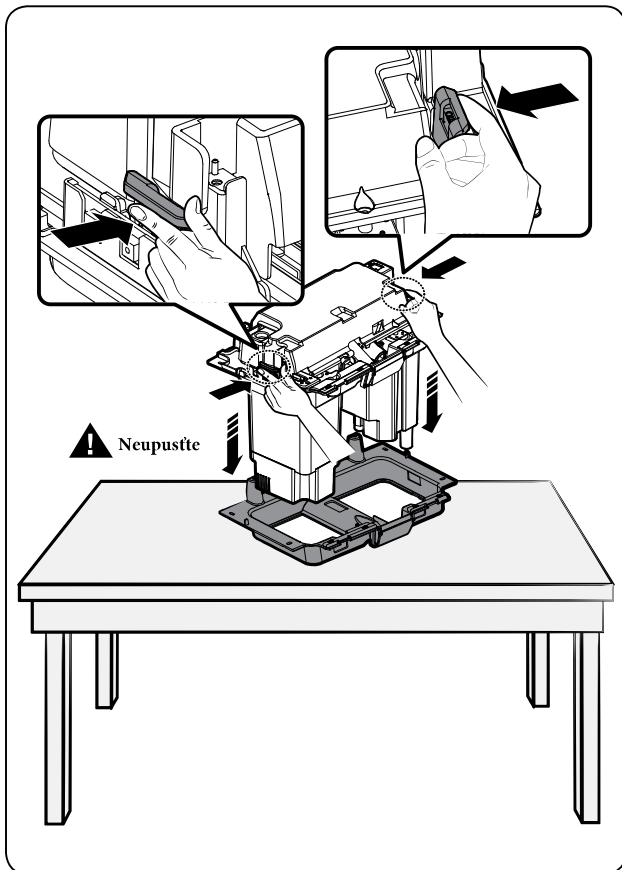

4-2

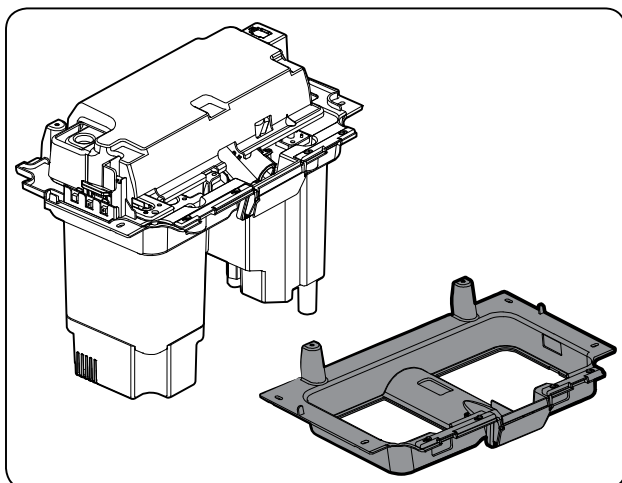

5

5-1

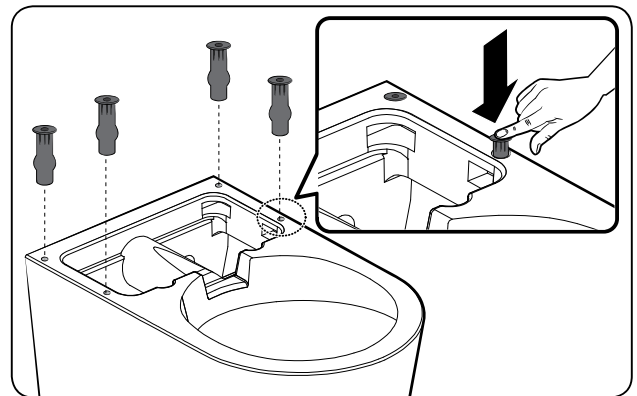

5-2

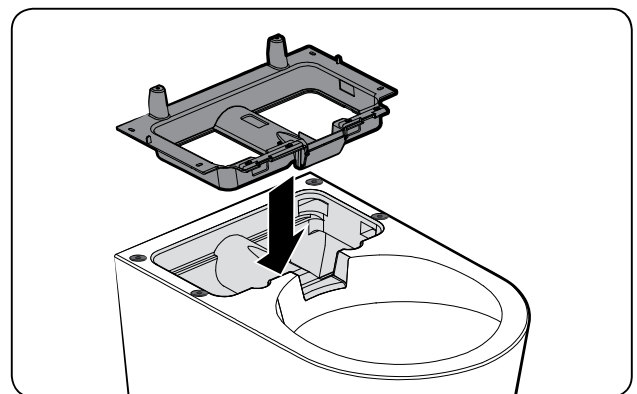

5-3

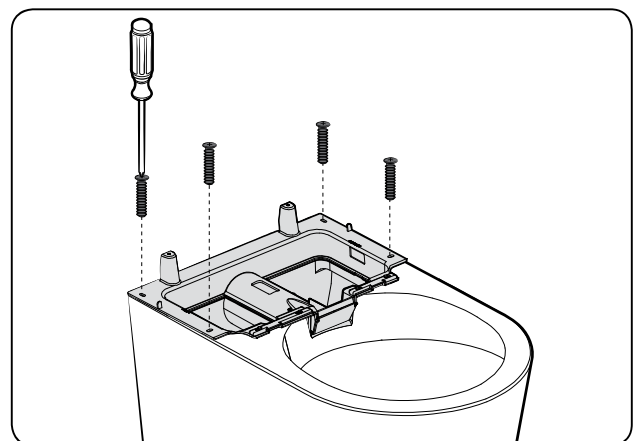



# 6

## 6-1

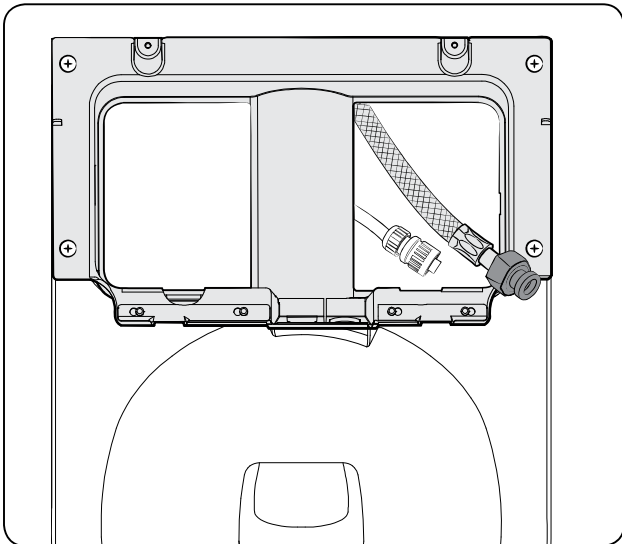

## 6-2

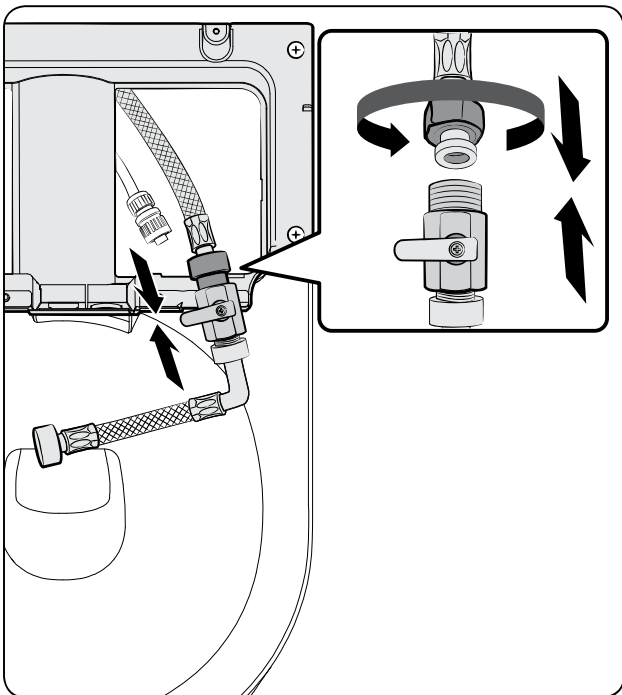

## 6-3

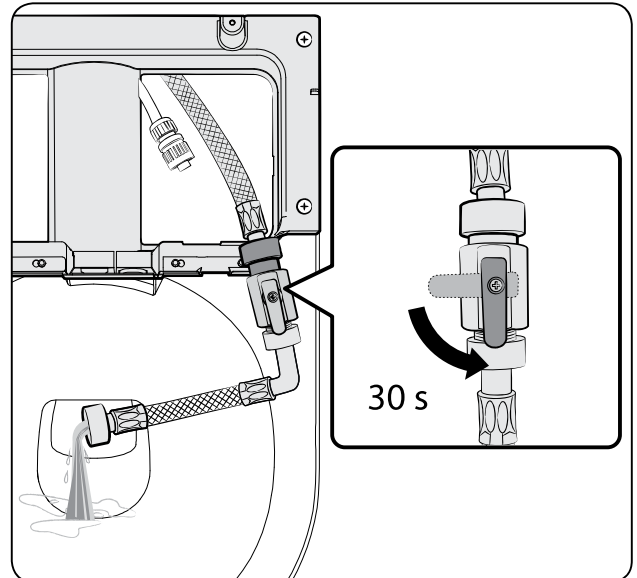

## 6-4

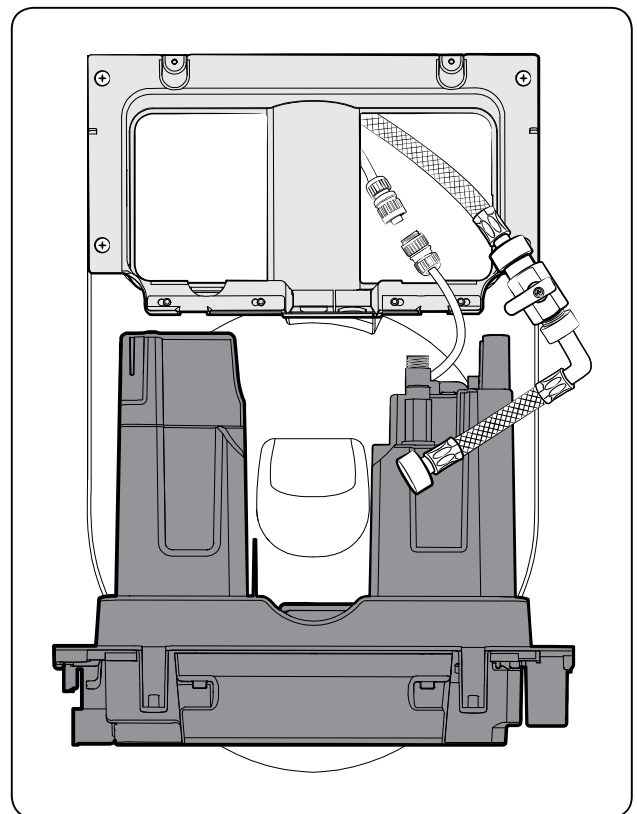

6-5

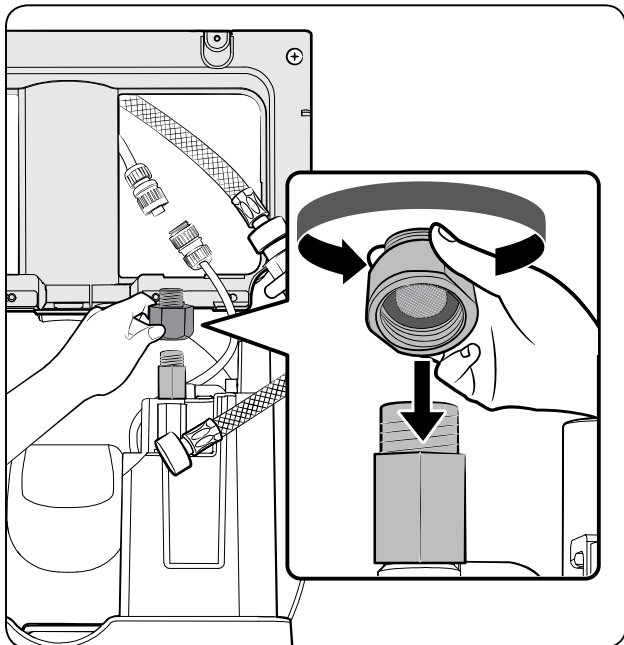

6-7

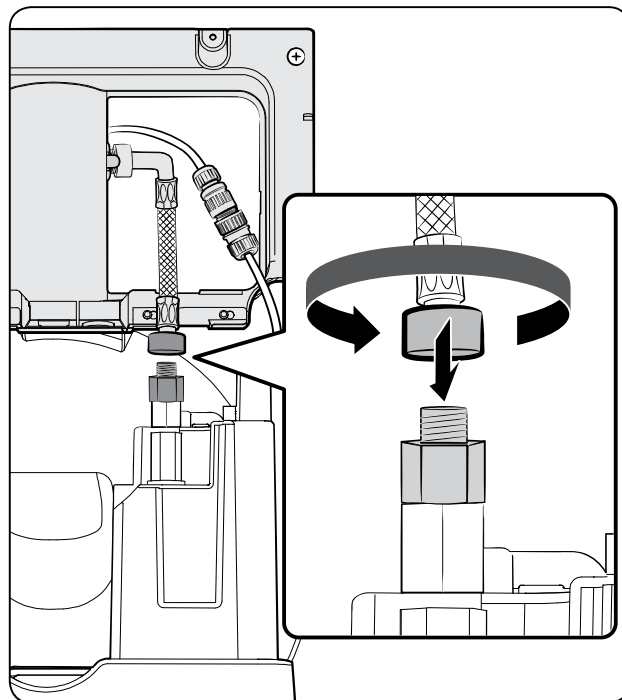

6-6

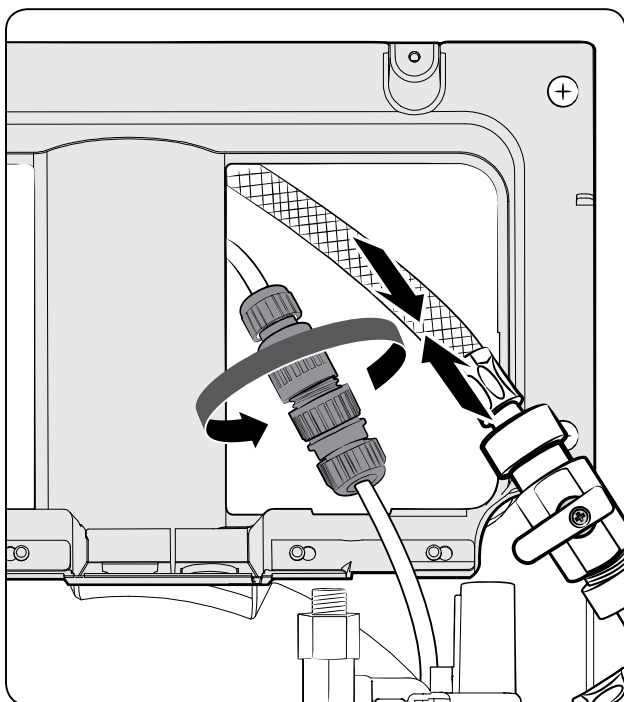

6-8

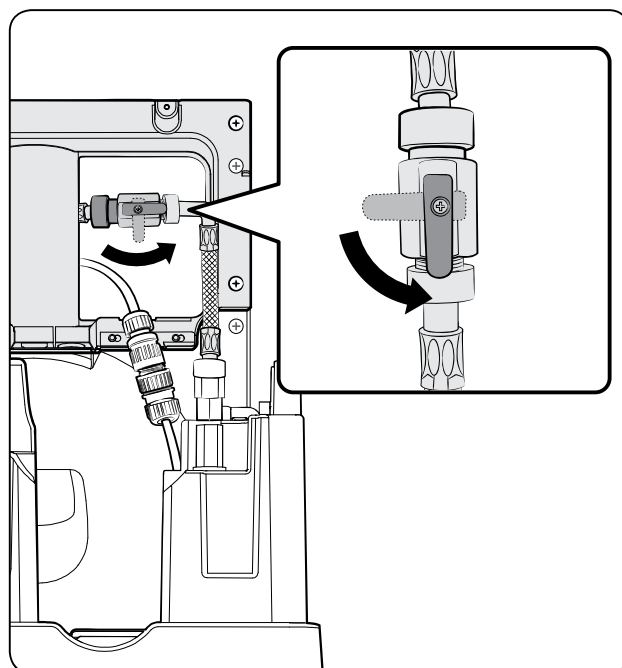

**7**

**7-1**

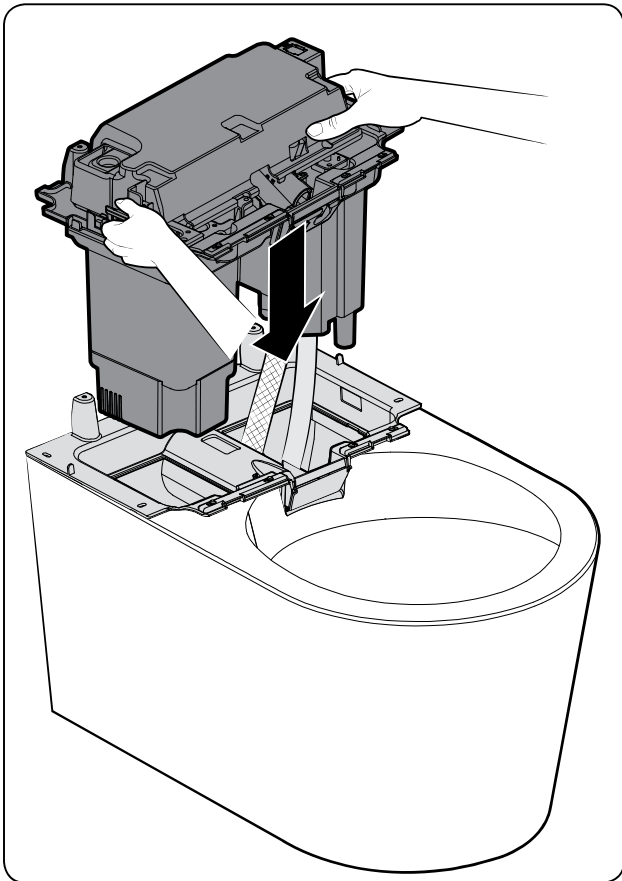

**7-2**

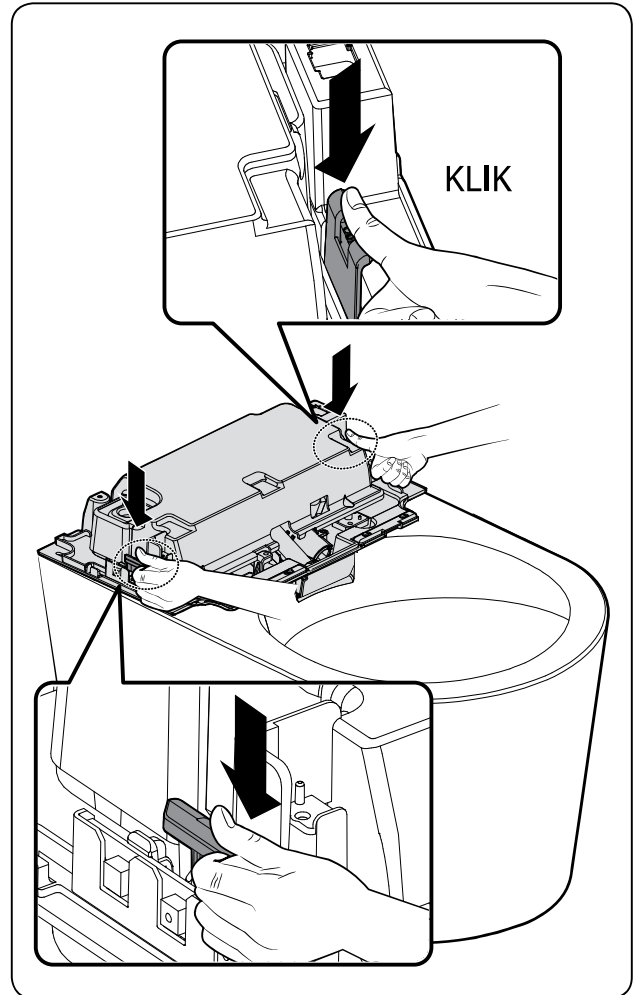

### 7-3

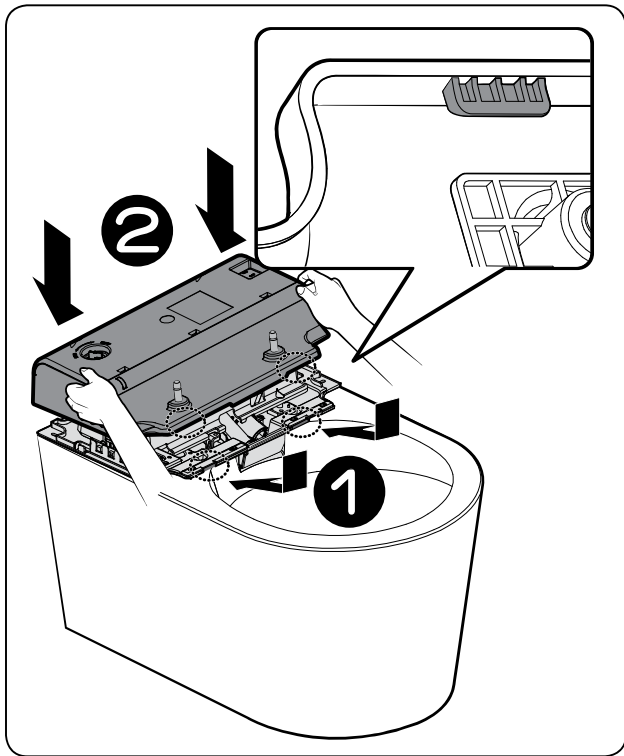

### 7-4

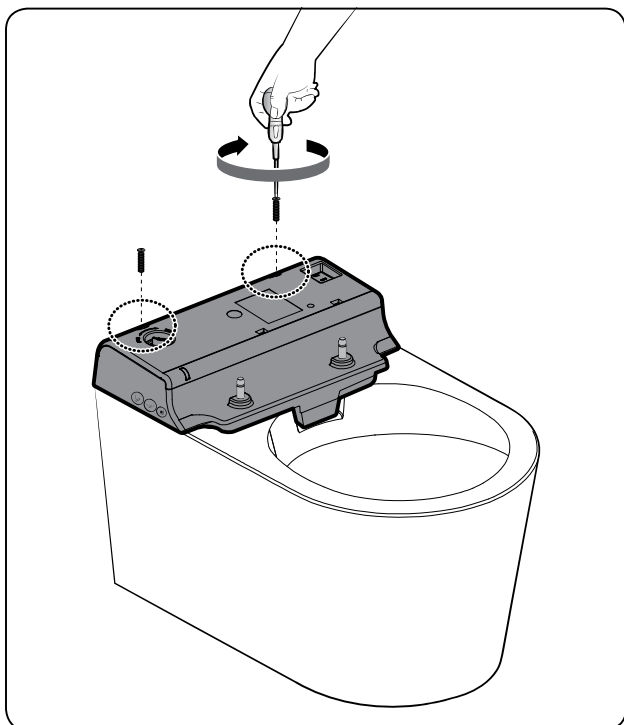

### 7-5

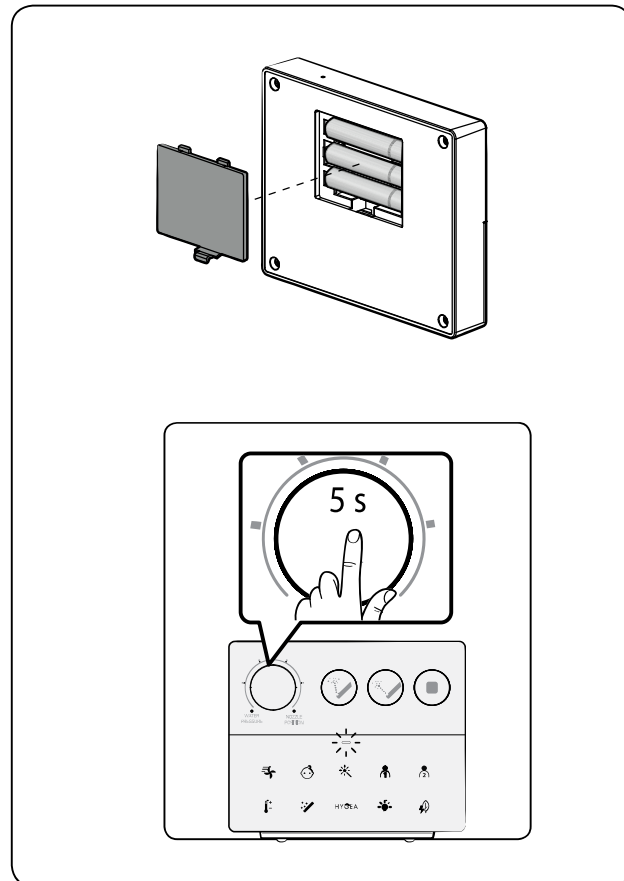

7-6

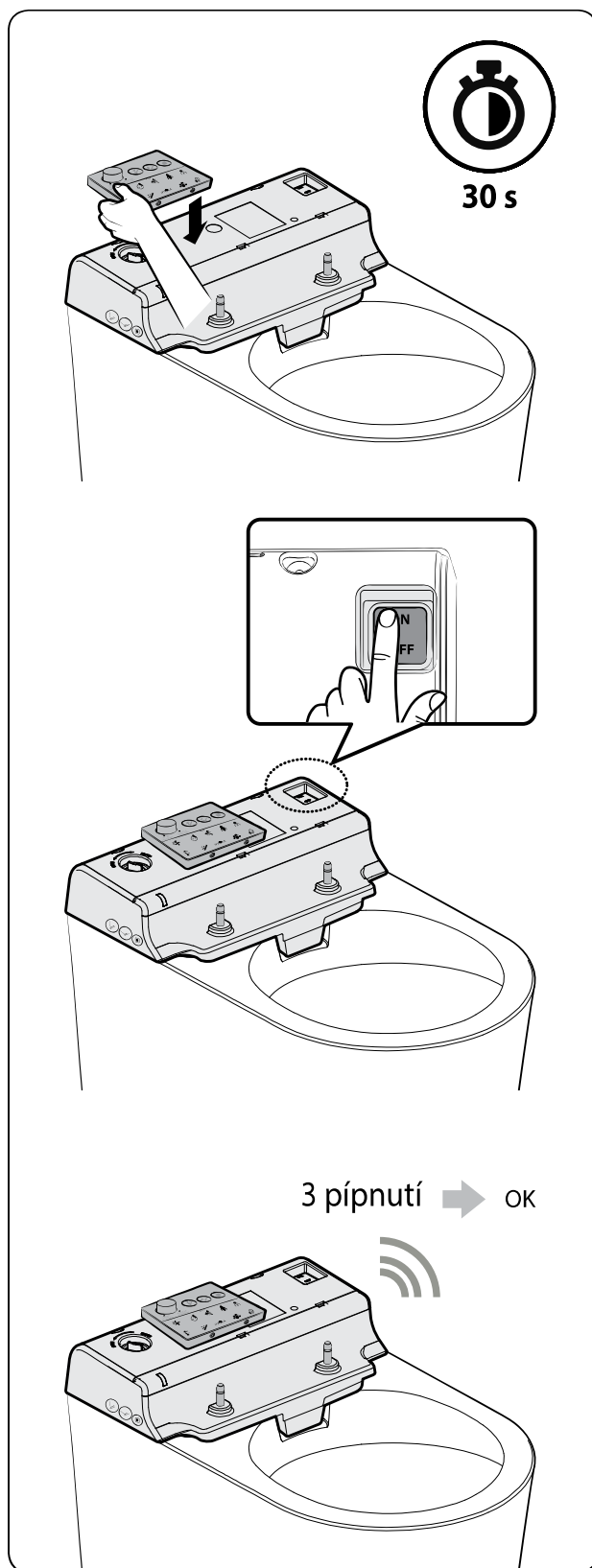

7-7

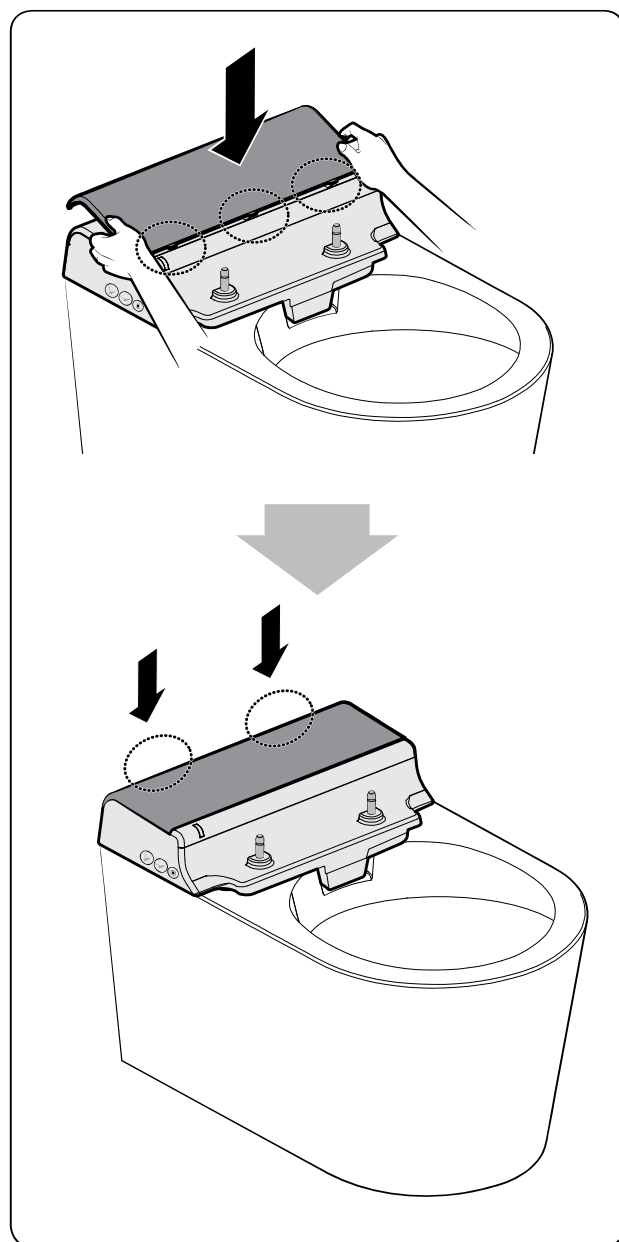

7-8

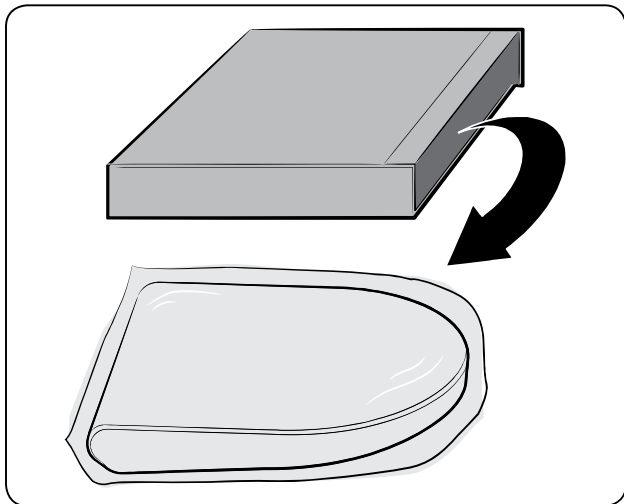

7-9

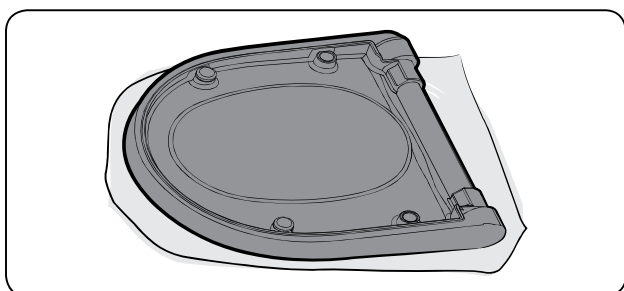

7-10

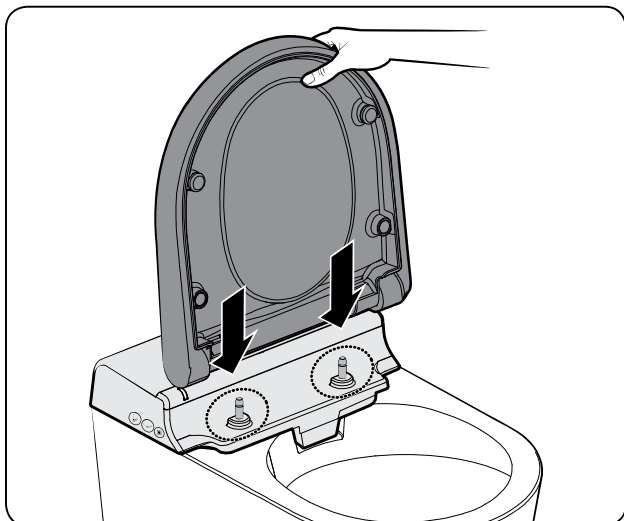

8

8-1

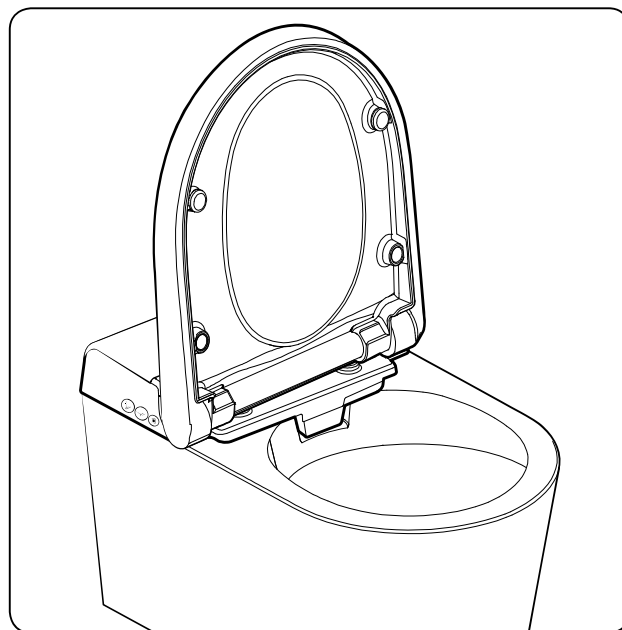

8-2

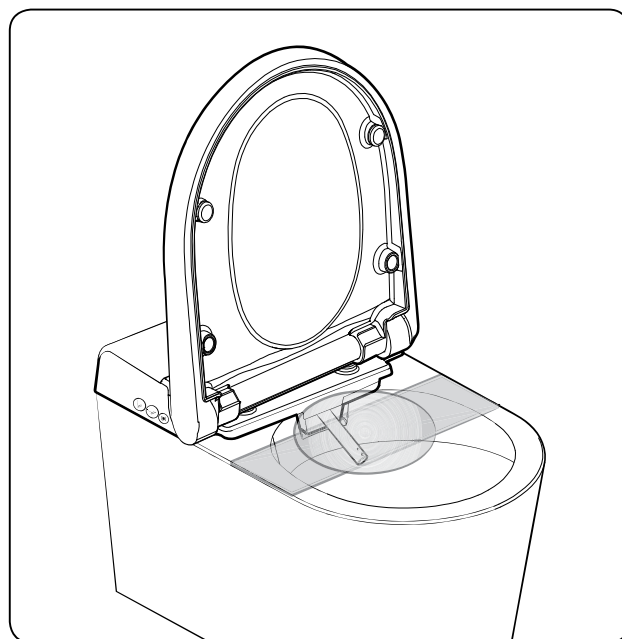

8-3

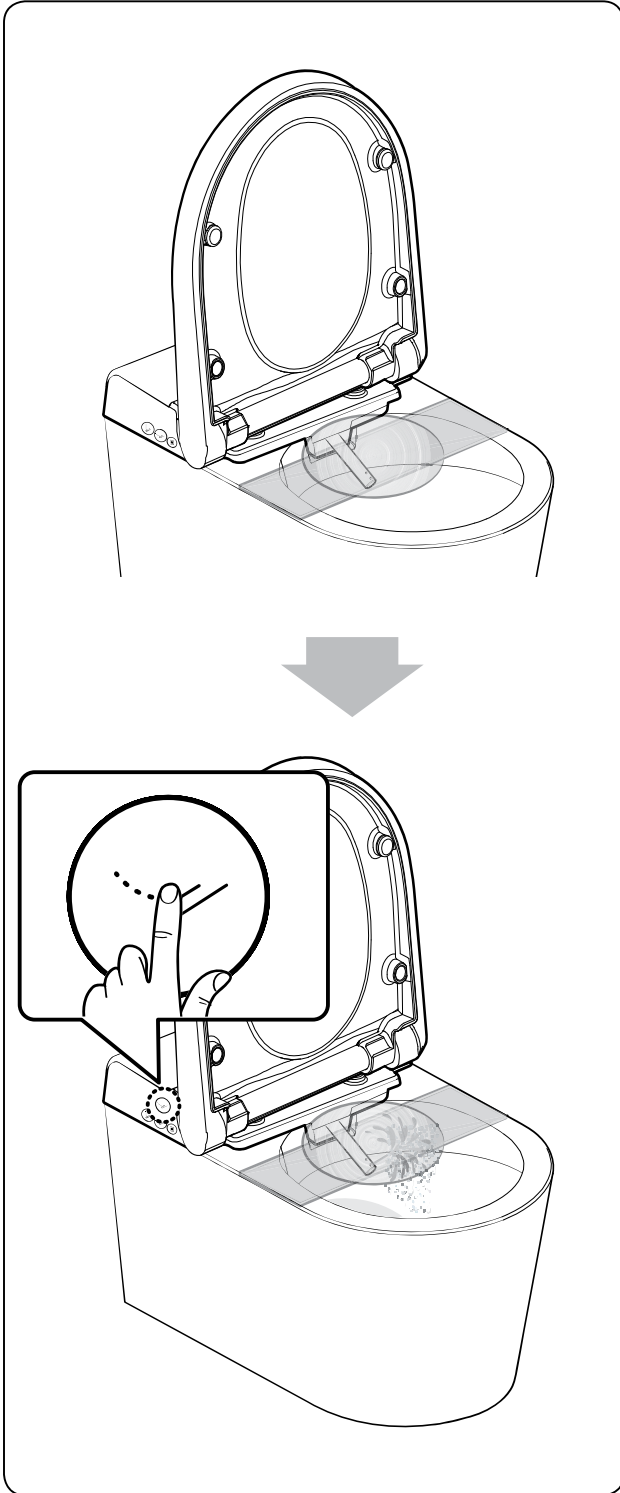

9

9-1

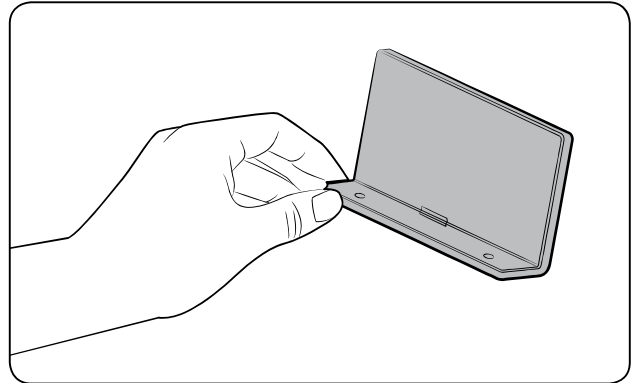

9-2

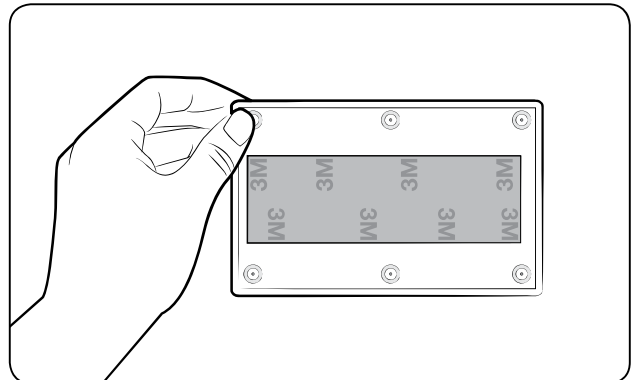

9-3

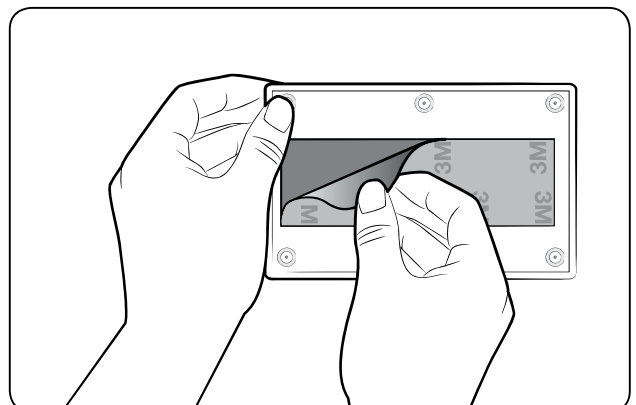

## 9-4

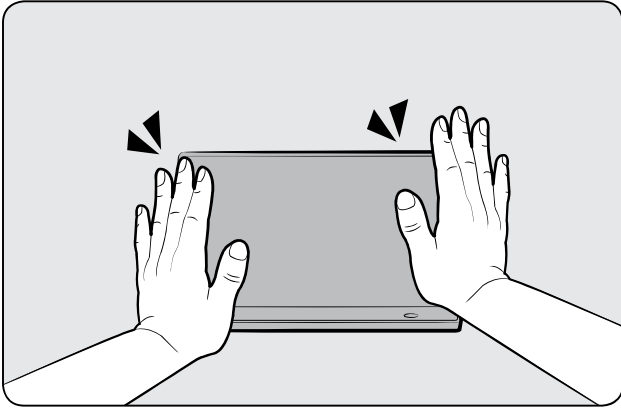

## 9-5

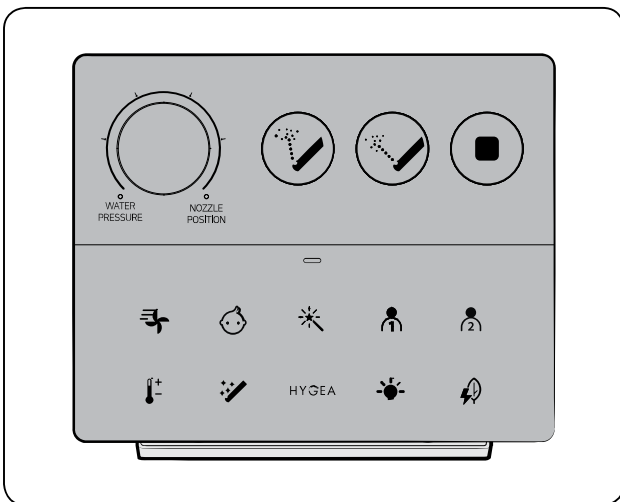

## 9-6

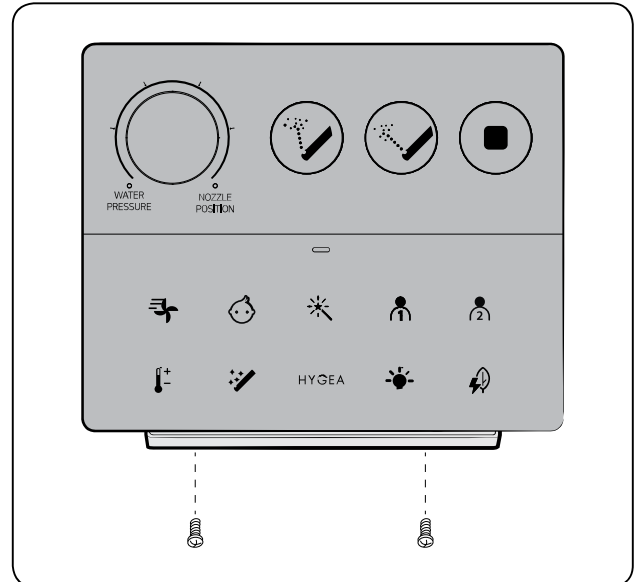

## 9-7

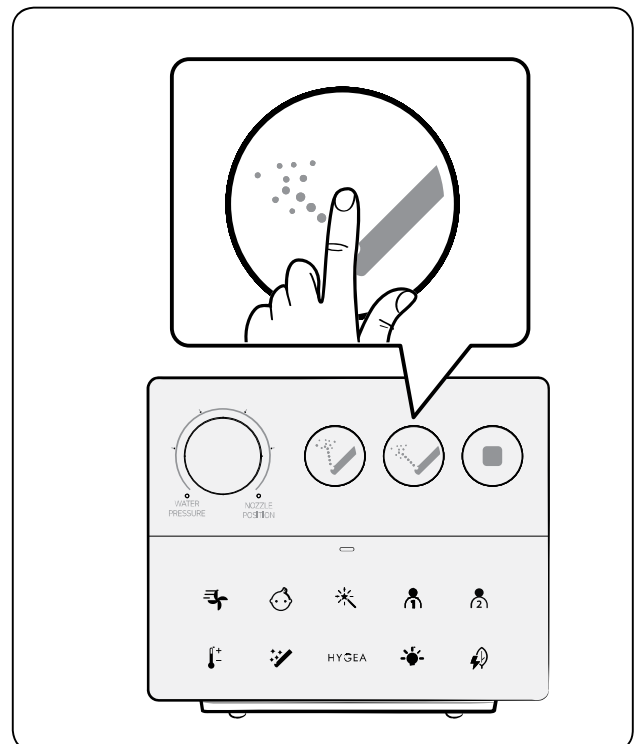



---

**9-8**

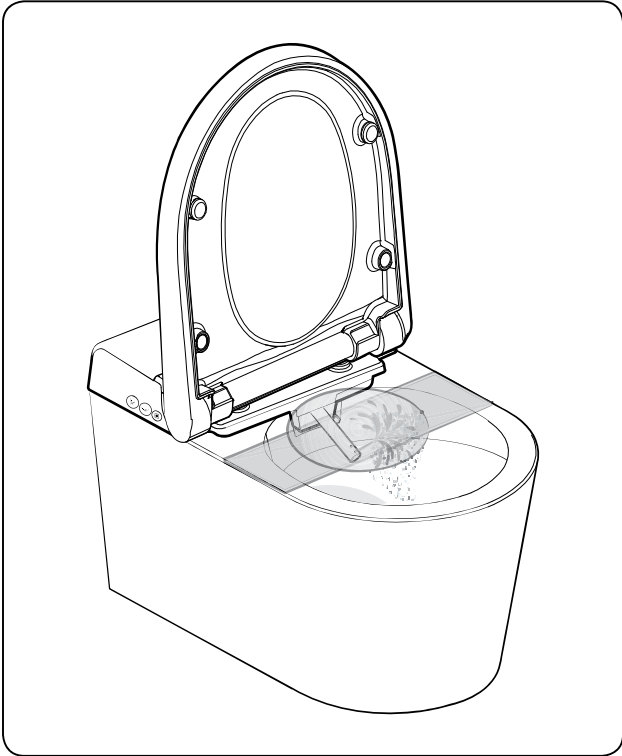

Dodavatel:



**PRAHA**

Ronkova 13/353  
180 00 Praha 8

Tel./fax: 266 313 652

ortoservis@ortoservis.cz

**BRNO**

Minská 100  
616 00 Brno - Žabovřesky

Tel./fax: 541 240 393

brno@ortoservis.cz

**ČESKÉ BUDĚJOVICE**

Staroměstská 2608  
370 04 České Budějovice

Tel./fax: 387 432 502

cb@ortoservis.cz

**OPAVA**

Pivovarská 7/71  
746 01 Opava

Tel./fax: 553 775 226

opava@ortoservis.cz

[www.ortoservis.cz](http://www.ortoservis.cz)

Společnost je zapsána v OR u Městského soudu v Praze, oddíl C, vložka 72014. IČ: 26121760